



# PROJECT CONCEPT NOTE

CARBON OFFSET UNIT (CoU) PROJECT



**Title: 5 MW Biomass based power supply to grid at Maizapur, Uttar Pradesh**

Version 2.0

Date: 20/06/2024

First CoU Issuance Period: 2 years, and 0 month

Date: 24/12/2021 to 23/12/2023



Project Concept Note (PCN)  
CARBON OFFSET UNIT (CoU) PROJECT

**BASIC INFORMATION**

Title of the project activity	5 MW Biomass based power supply to grid at Maizapur, Uttar Pradesh
Scale of the project activity	Large Scale
Completion date of the PCN	20/06/2024
Project participants	First Climate (India) Private Limited (Aggregator) Balrampur Chini Mills Limited (Developer)
Host Party	India
Applied methodologies and standardized baselines	CDM UNFCCC Methodology ACM0006: Electricity and heat generation from biomass (version 16.0)
Sectoral scopes	01 Energy industries (Renewable/Non Renewable Sources)
Estimated amount of total GHG emission reductions	17,496 CoUs/year (17,496 tCO <sub>2e</sub> /year)

## **SECTION A. Description of project activity**

### **A.1. Purpose and general description of Carbon offset Unit (CoU) project activity >>**

The project activity involves 5 MW bagasse fuelled green power supply to grid. The project is developed by Balrampur Chini Mills Limited. Location of the project activity is in Village Maizapur, Tehsil Colonelganj, District Gonda, State Uttar Pradesh, and Country India.

The details of the registered project are as follows:

#### **Purpose of the project activity:**

Maizapur Chini Mills is a unit of Balrampur Chini Mills Limited., located in Maizapur village of Gonda district, Uttar Pradesh. Plant has installed two biomass fired boilers of capacities 35 TPH each. The boilers are connected with a common steam header and together connected to two turbines, of capacity 5.085 MW each. The cogeneration facility generates steam for both process needs and meeting the electricity requirements of the plant. After meeting the in-house demand of electricity, surplus electricity is exported to the grid. The state discom, Uttar Pradesh Power Corporation Limited (UPPCL) has signed a PPA on 20/11/2020 for 5 MW power supply. The purpose of the project activity is to provide renewable electricity to the grid, thereby increasing the percentage of renewable energy in the present grid mix.

In absence of the project activity, equivalent amount of electricity which is supplied by this project activity would have been supplied to the grid by predominantly fossil fuel based power plant(s) connected to this grid. The plant commissioning date is 24/12/2021. Hence start date of the crediting period is also considered from 24/12/2021.

Thus the project activity would replace the fossil fuel dominated electricity with green electricity, which would have otherwise been supplied by the fossil fuel dominated thermal power plant connected to the grid. Biomass is a renewable source of energy and also considered as carbon neutral. In the project activity the preferred biomass is bagasse. The industry being a sugar mill and bagasse being its own process waste, CoUs shall only be claimed for the quantity of electricity exported to the grid. Hence the project activity is expected to reduce the anthropogenic Greenhouse gas (GHG) emissions by 17,496 tCO<sub>2</sub>e/year.





## A.2 Do no harm or Impact test of the project activity>>

There are social, environmental, economic and technological benefits which contribute to sustainable development.

- **Social benefits:**
  - Employment for skilled, semi-skilled and unskilled labour in the project location for operational and maintenance of the equipments.
  - The plant will inspire renewable energy adoption in the nearby areas and educate people on the benefits of adopting more sustainable lifestyles.
- **Environmental benefits:**
  - Replacing fossil fuels such as coal with renewable resources like biomass, will reduce the greenhouse gas emissions globally in the atmosphere.
  - Project activity uses bagasse as a fuel for boilers which is an industrial biomass residue that is being repurposed. This promotes efficient waste management and handling practices.
  - Using renewable energy resources, the demand for consumption of fossil fuel will also decrease; in order to shift to clean and green energy. Renewable energy so supplied to state grid, which is further connected to the national grid increases green electricity availability for consumers.
- **Economic benefits:**
  - The project activity will reduce the production facility's dependence on fossil fuel. This will reduce the overall dependence of the whole region on fossil fuel imports, benefitting the country's foreign exchange reserves.
- **Technically well-being:**
  - The technology being adopted is a good example of application of established technologies developed within the country for power generation, thus positively contributing to the technological well-being.

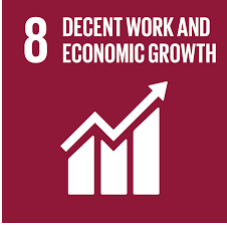
The project activity, beside "Climate action" (i.e., SDG 13), addresses multiple other UN SDGs too. The list of the SDGs addressed through the Project is mentioned below:

SDG	The Project contributes to	Description of contribution
 <p><b>SDG 7:</b> <b>Affordable and Clean Energy</b></p>	<p>Target: 7.1 Indicator: 7.1.2</p> <p>Target: 7.2 Indicator: 7.2.1</p> <p>Target: 7.a Indicator: 7.a.1</p> <p>Target: 7.b Indicator: 7.b.1</p>	<p>Biomass fired system is a carbon neutral system and by requesting submission of this project under UCR, the project owner is evidently seeking international cooperation to facilitate investment into clean energy infrastructure.</p> <p>By using bagasse based fired system, the demand of fossil fuels is reduced. Also bagasse is considered as renewable</p>

 <p><b>SDG 8:</b> <b>Decent work and Economic Growth</b></p>	<p>Target: 8.4 Indicator: 8.4.1</p>	<p>source.</p> <p>By using renewable energy sources for economic productivity to achieve same outcomes at the process level- the project owner aims to decouple environmental degradation, global warming and climate crisis from economic productivity.</p>
 <p><b>SDG 9:</b> <b>Industry, Innovation and Infrastructure</b></p>	<p>Target: 9.4 Indicator: 9.4.1</p>	<p>The project directly contributes to abatement of carbon dioxide emissions.</p>
 <p><b>SDG 12:</b> <b>Responsible Consumption and Production</b></p>	<p>Target: 12.2 Indicator: 12.2.1</p> <p>Target: 12.5 Indicator: 12.5.1</p> <p>Target: 12.a Indicator: 12.a.1</p>	<p>As bagasse cannot be processed or used further by the sugar industry it is considered as an industrial waste product. Hence the waste is been utilized which would otherwise have been dumped.</p>
 <p><b>SDG 13:</b> <b>Climate Action</b></p>	<p>Target: 13.2 Indicator: 13.2.2</p>	<p>Biomass based systems reduce the GHG emissions of the planet at large.</p>

### A.3. Location of project activity >>

Country: India  
District: Gonda  
Village: Maizapur  
Tehsil: Colonelganj  
State: Uttar Pradesh  
Postal Code: 271126

The project site is well connected by district and village roads to the nearest town. The geographic co-ordinates of the project location are:

Latitude: 27.1666 N  
Longitude: 81.7890 E

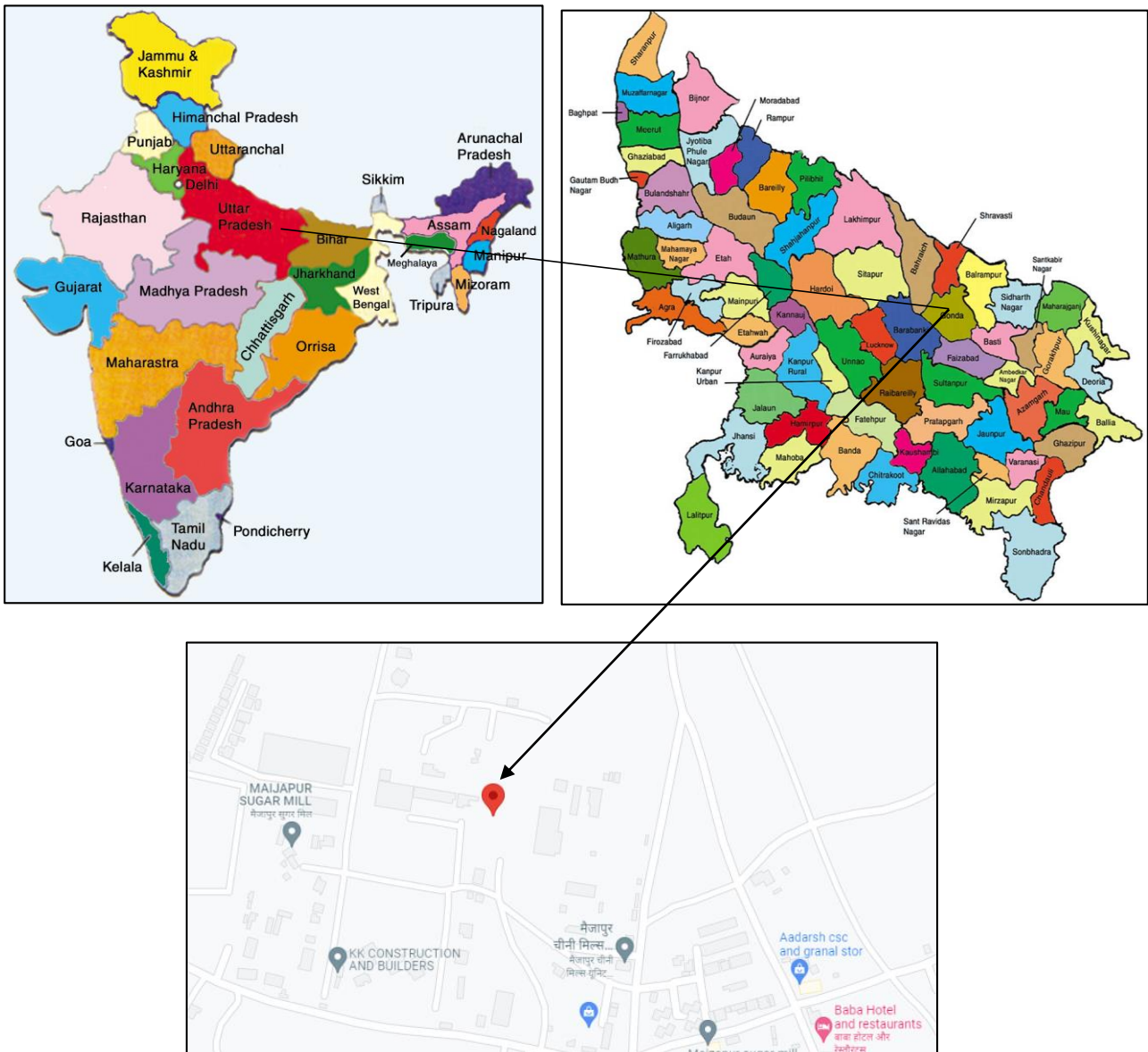

Figure 1: Map showing the exact location of the project activity

#### A.4. Technologies/measures >>

Process flow chart:

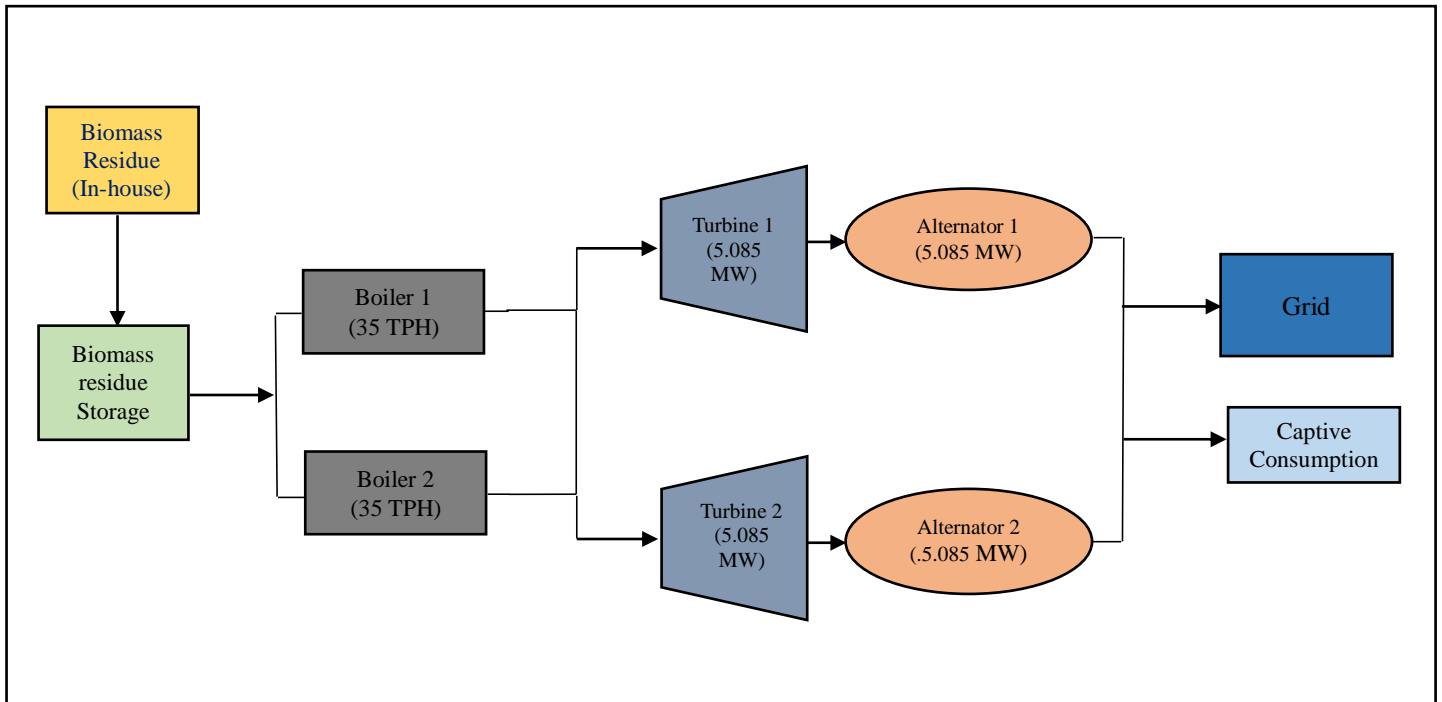

Figure 2: Schematic representation of the process flow chart

The project activity involves generation of both thermal and electrical energy from the combustion of renewable biomass i.e. bagasse, to generate process steam and electricity for captive consumption and grid supply. The technology employed is a biomass-based cogeneration system, i.e., generating steam and electricity. Thus, the technology to be used in this project is environmentally safe & sound. Emission reductions will be claimed for electricity exported to the grid only.

Details of the technical concept is as follows:

The sugar mill demands both electrical and thermal energy to run the process. To meet the demand, plant has installed a biomass fired co-generation system at their facility.

Technical details of boilers and turbines are tabulated below:

Boilers:

Parameter	Unit	Boiler 1	Boiler 2
Boiler rated capacity	TPH	35	35
Nameplate Steam Pressure	kg/cm <sup>2</sup> (G)	45	45
Nameplate Steam Temperature	Deg. C	420	420
Fuel Type	-	Bagasse	Bagasse



Turbines:

Parameter	Unit	Turbine 1	Turbine 2
Inlet steam pressure	ata	45	45
Inlet steam temperature	Deg. C	415	415
Extraction pressure	ata	2.25	2.25
Rated power	KW	5085	5085

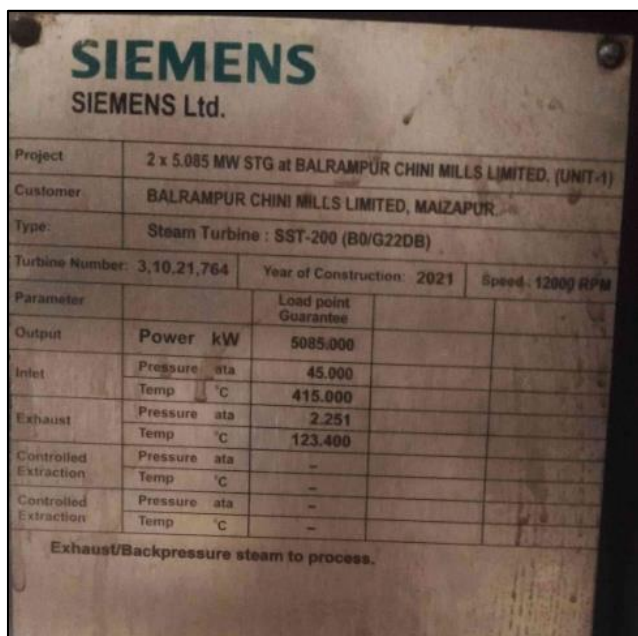

Figure 3: Nameplates of turbines within the plant

### A.5. Parties and project participants >>

Party (Host)	Participants
India	<p><b>First Climate (India) Private Limited (AGGREGATOR)</b></p> <p>Contact person: Partha P Chaudhuri Mobile: +91 9831012824</p> <p>Address: 903, ERGO Tower, Plot No. A1-4, Block EP &amp; GP, Sector V, Salt Lake, Kolkata 700 091</p>



	<p><b>Balrampur Chini Mills Limited (DEVELOPER)</b></p> <p>Phone: (033) 2287-4749</p> <p>Address: “FMC FORTUNA” 2<sup>nd</sup> floor, 234/3A, A.J.C Bose road Kolkata 700 020</p>
--	---

**A.6. Baseline Emissions>>**

The baseline scenario identified at the PCN stage of the project activity is:

In absence of the project activity, the energy supplied by the plant to grid would have been supplied by fossil fuel dominated power plants connected to the grid. Due to the combustion of fossil fuel such as coal, emissions of carbon dioxide would have occurred. Since the project activity is using bagasse as fuel, which is a renewable and carbon neutral fuel, it is reducing greenhouse gas emissions by avoiding combustion of coal / fossil fuels.

**BASELINE SCENARIO**

Electricity and heat would be produced by more-carbon-intensive technologies based on fossil fuel or less-efficient biomass power and heat plants. Biomass could partly decay under anaerobic conditions, bringing about methane emissions.

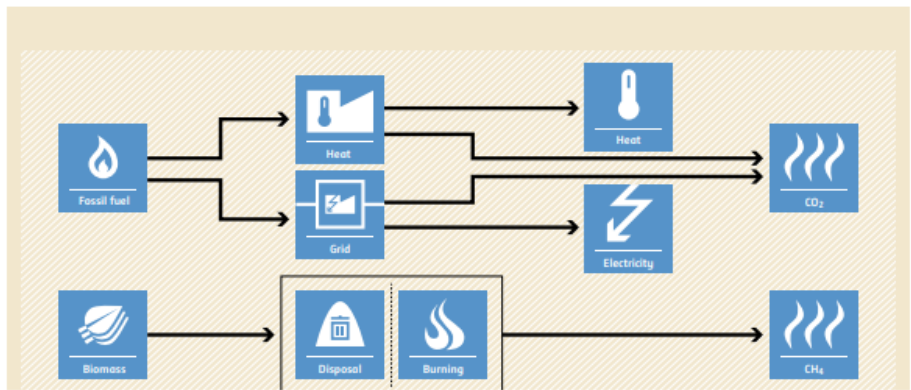

**PROJECT SCENARIO**

Use of biomass for power and heat generation instead of fossil fuel or increase of the efficiency of biomass-fuelled power and heat plants. Biomass is used as fuel and decay of biomass is avoided.

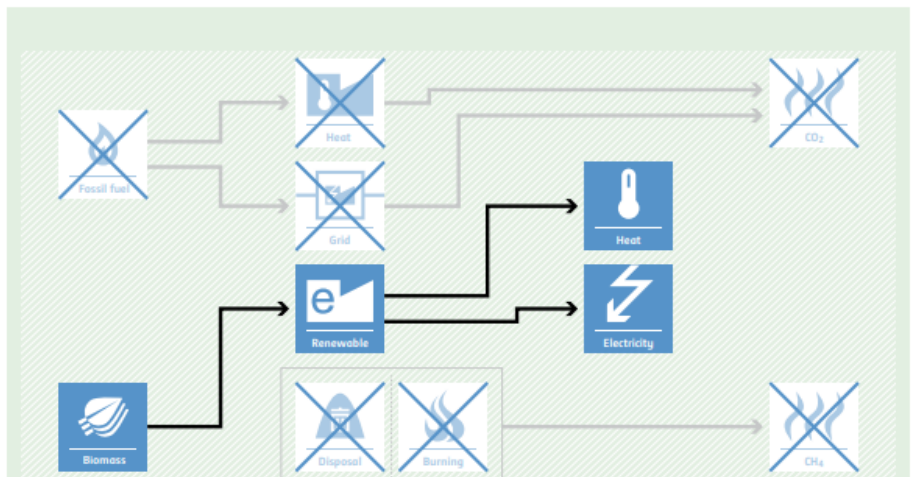

Figure 4: Diagram showing the comparison between baseline scenario and the project activity

#### **A.7. Debundling>>**

This project is a greenfield project and not a debundled component of a larger project activity. The project can be tracked using its unique geo-coordinates. The project activity is a greenfield project activity and neither was registered in any other GHG mechanism nor was rejected by any GHG mechanism.

## SECTION B. Application of methodologies and standardized baselines

### B.1. References to methodologies and standardized baselines >>

<b>SECTORAL SCOPE</b> –	01 Energy industries (Renewable/Non-renewable sources)
<b>TYPE</b> -	I - Renewable Energy Projects
<b>CATEGORY</b> -	ACM0006 Electricity and heat generation from biomass (Version 16.0)

### B.2. Applicability of methodologies and standardized baselines >>

<b>Applicability Criteria</b>	<b>Project Condition</b>
<p><i>“The methodology is applicable under the following conditions:</i></p> <p><i>(a) Biomass used by the project plant is limited to biomass residues, biogas, RDF and/or biomass from dedicated plantations;</i></p> <p><i>(b) Fossil fuels may be co-fired in the project plant. However, the amount of fossil fuels co-fired does not exceed 80% of the total fuel fired on energy basis;</i></p> <p><i>(c) For projects that use biomass residues from a production process (e.g. production of sugar or wood panel boards), the implementation of the project does not result in an increase of the processing capacity of (the industrial facility generating the residues) raw input (e.g. sugar, rice, logs, etc.) or in other substantial changes (e.g. product change) in this process;</i></p> <p><i>(d) The biomass used by the project plant is not stored for more than one year;</i></p> <p><i>(e) The biomass used by the project plant is not processed chemically or biologically (e.g. through esterification, fermentation, hydrolysis, pyrolysis, bio- or chemical degradation, etc.) prior to combustion. Drying and mechanical processing, such as shredding and pelletisation, are allowed.”</i></p>	<p><b>Applicable</b></p> <p>Project activity uses bagasse as renewable biomass which is a biomass residue. There is surplus availability of bagasse in India and hence the implementation of the project does not negatively impact other operations or industries. The bagasse is used without any chemical or biological processes. Biomass used is not stored more than one year.</p> <p>Hence the points (a), (b), (c), (d), (e) are applicable.</p>
<p><i>“In the case of fuel switch project activities, the</i></p>	<p><b>Not Applicable</b></p>

<p><i>use of biomass or the increase in the use of biomass as compared to the baseline scenario is technically not possible at the project site without a capital investment in:</i></p> <p><i>(a) The retrofit or replacement of existing heat generators/boilers; or</i></p> <p><i>(b) The installation of new heat generators/boilers; or</i></p> <p><i>(c) A new dedicated supply chain of biomass established for the purpose of the project (e.g. collecting and cleaning contaminated new sources of biomass residues that could otherwise not be used for energy purposes); or</i></p> <p><i>(d) Equipment for preparation and feeding of biomass.”</i></p>	<p>It is not a fuel switch project activity. Hence the criteria is not applicable.</p>
<p><i>“If biogas is used for power and heat generation, the biogas must be generated by anaerobic digestion of wastewater, and:</i></p> <p><i>(a) If the wastewater generation source is registered as a CDM project activity, the details of the wastewater project shall be included in the PDD, and emission reductions from biogas energy generation are claimed using this methodology;</i></p> <p><i>(b) If the wastewater source is not a CDM project, the amount of biogas does not exceed 50% of the total fuel fired on energy basis”</i></p>	<p><b>Not Applicable</b></p> <p>Biogas is not produced in the project activity. So the criteria is not applicable.</p>
<p><i>“In the case biomass from dedicated plantations is used, the “TOOL16: Project and leakage emissions from biomass” shall apply to determine the relevant project and leakage emissions from cultivation of biomass and from the utilization of biomass residues.”</i></p>	<p><b>Not Applicable</b></p> <p>The biomass residue is an industrial waste of sugarcane processing and no dedicated plantation is used to obtain this residue. There are no project and leakage emissions as the plant uses its own waste. Hence the criterion is not applicable.</p>
<p><i>“The methodology is only applicable if the baseline scenario, as identified per the “Selection of the baseline scenario and demonstration of additionality” section hereunder, is:</i></p> <p><i>(a) For power generation: scenarios P2 to P7, or a combination of any of those scenarios; and</i></p> <p><i>(b) For heat generation: scenarios H2 to H7, or a combination of any of those scenarios;</i></p> <p><i>(c) If some of the heat generated by the CDM project activity is converted to mechanical power through steam turbines, for mechanical power generation: scenarios M2 to M5:</i></p> <p><i>(i) In cases M2 and M3, if the steam turbine(s) are used for mechanical power in the project,</i></p>	<p><b>Applicable</b></p> <p>This project activity uses biomass derived as a by-product from their manufacturing process within project boundary and therefore is claiming the emission reduction credits for only the renewable energy powered electricity exported to the grid. Hence, in this document, (b), (c), (d) and (e) are not considered.</p>

<p><i>the turbine(s) used in the baseline shall be at least as efficient as the steam turbine(s) used for mechanical power in the project;</i></p> <p><i>(ii) In cases M4 and M5, steam turbine(s) generating mechanical power to be used for the same purpose as in the baseline are not allowed;</i></p> <p><i>(d) For the use of biomass residues: scenarios B1 to B5, or a combination of any of those scenarios;</i></p> <p><i>(e) For the use of biogas: scenarios BG1 to BG3, or a combination of any of those scenarios.”</i></p>	
---	--

### **B.3. Applicability of double counting emission reductions >>**

There is no double accounting of emission reductions in the project activity due to the following reasons:

- Project has dedicated commissioning certificate and connection point.
- The project is a new green field project and neither registered previously in any other voluntary or compliance program, nor a de-bundled component of any large scale project or Programme of Activities (PoA).
- No previous project was located at the same location.

### **B.4. Project boundary, sources and greenhouse gases (GHGs)>>**

The project is within the industrial facility of Maizapur Chini Mills, which is a plant of Balrampur Chini Mills Limited. The project boundary encompasses equipments installed for the operation of cogeneration plant, which includes two boilers of capacities 35 TPH each. The two boilers are connected to, two turbines of rated power capacities of 5.085 MW each. Beside this, the biomass storage facility, the facility (i.e., sugar unit) consuming the energy (both electrical and thermal) so generated by the project activity and the supply of surplus electricity to the grid are also included in the project boundary.

Plant would use biomass residues like bagasse as fuel for the boiler. Quantity of the biomass required would be generated in-house as bagasse is produced as a process waste of the sugar mill.

Project boundary of this project is illustrated below:

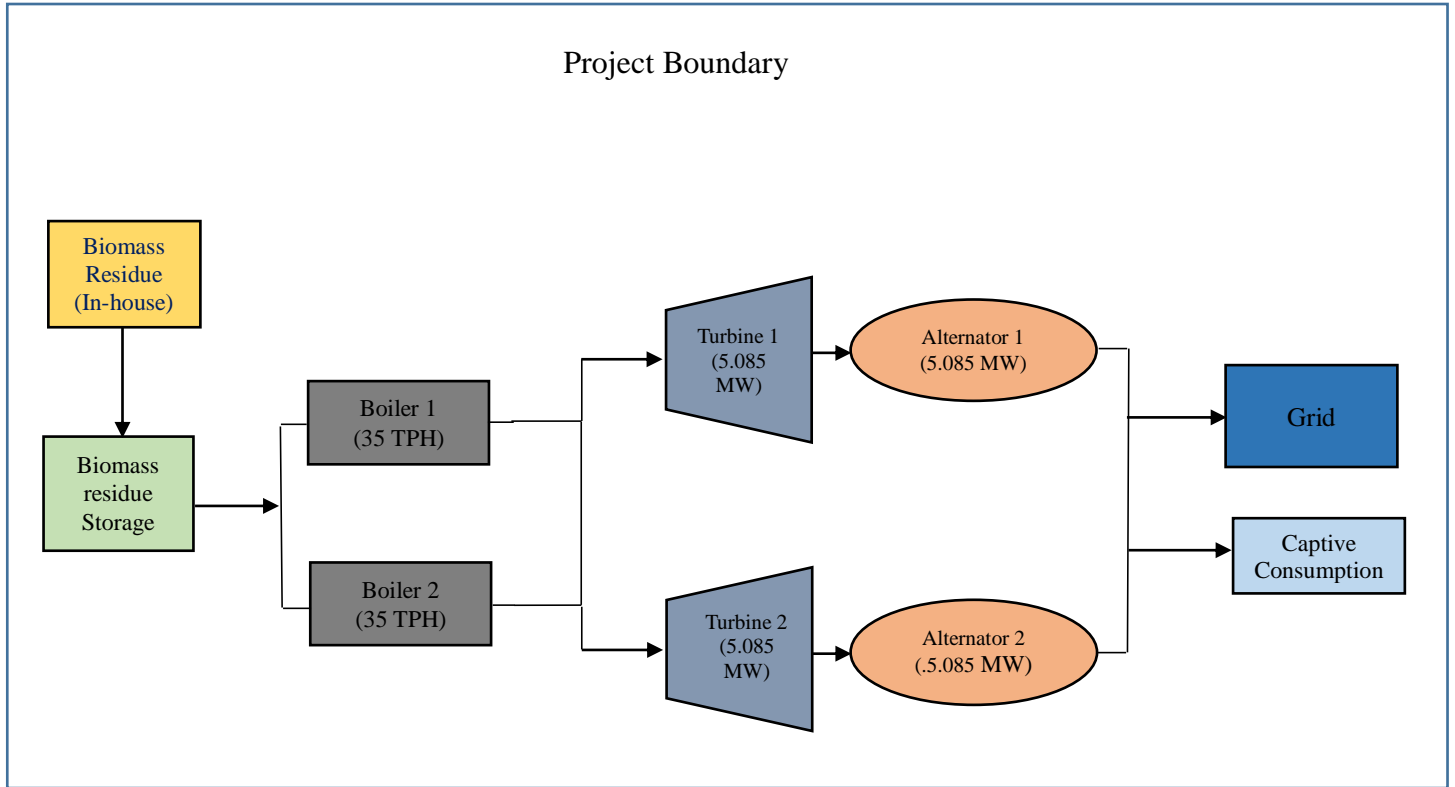

Figure 5: Schematic representation of project boundary

The table below provides an overview of the emission sources included or excluded from the project boundary for determination of baseline and project emission:

Source		Gas	Included	Justification
Baseline	Electricity and heat generation	CO <sub>2</sub>	Yes	Main emission source
		CH <sub>4</sub>	No	Excluded for simplification. This is conservative
		N <sub>2</sub> O	No	Excluded for simplification.
	Uncontrolled burning or decay of surplus biomass residues	CO <sub>2</sub>	No	Excluded for simplification.
		CH <sub>4</sub>	No	Excluded for simplification.
		N <sub>2</sub> O	No	Excluded for simplification.
Project Activity	On-site fossil fuel consumption	CO <sub>2</sub>	No	Project activity does not use fossil fuel.
		CH <sub>4</sub>	No	Project activity does not use fossil fuel.
		N <sub>2</sub> O	No	Project activity does not use fossil fuel.
	Off-site	CO <sub>2</sub>	No	Biomass is not

	transportation of biomass			transported outside the plant premises.
		CH <sub>4</sub>	No	Biomass is not transported outside the plant premises.
		N <sub>2</sub> O	No	Biomass is not transported outside the plant premises.
	Combustion of biomass for electricity and heat	CO <sub>2</sub>	No	Biomass is a carbon neutral fuel.
		CH <sub>4</sub>	No	Not applicable, as not considered in baseline scenario.
		N <sub>2</sub> O	No	Excluded for simplification. This emission source is assumed to be small
	Wastewater from the treatment of biomass	CO <sub>2</sub>	No	Biomass does not undergo any treatment. So no wastewater is generated.
		CH <sub>4</sub>	No	Biomass does not undergo any treatment. So no wastewater is generated.
		N <sub>2</sub> O	No	Biomass does not undergo any treatment. So no wastewater is generated.
	Cultivation of land to produce biomass feedstock	CO <sub>2</sub>	No	Not applicable as biomass is not sourced from dedicated plantations.
		CH <sub>4</sub>	No	Not applicable as biomass is not sourced from dedicated plantations.
		N <sub>2</sub> O	No	Not applicable as biomass is not sourced from dedicated plantations.

### B.5. Establishment and description of baseline scenario (UCR Standard or Methodology) >>

In absence of the project activity equivalent energy would have been generated and supplied to the grid by the power plants connected to the grid which are dominated by fossil fuels.

Emission Reductions are calculated as follows:

$$ER_y = BE_y - PE_y - LE_y$$



Where,

$ER_y$  = Emissions reductions in year y (t CO<sub>2</sub>)

$BE_y$  = Baseline emissions in year y (t CO<sub>2</sub>)

$PE_y$  = Project emissions in year y (t CO<sub>2</sub>)

$LE_y$  = Leakage emissions in year y (t CO<sub>2</sub>)

Baseline emissions are calculated as follows:

$$BE_y = EL_{BL,GR,y} \times EF_{EG,GR,y} + \sum FF_{BL,HG,y,f} \times EF_{FF,y,f} + EL_{BL,FF/GR,y} \times \min(EF_{EG,GR,y}, EF_{EG,FF,y}) + BE_{BR,y}$$

Where,

$BE_y$  = Baseline emissions in year y (t CO<sub>2</sub>)

$EL_{BL,,}$  = Baseline electricity sourced from the grid in year y (MWh)

$EF_{EG,GR,y}$  = Grid emission factor in year y (t CO<sub>2</sub>/MWh)

$FF_{BL,HG,y,f}$  = Baseline fossil fuel demand for process heat in year y (GJ)

$EF_{FF,y,f}$  = CO<sub>2</sub> emission factor for fossil fuel type f in year y (t CO<sub>2</sub>/GJ)

$EL_{BL,FF/GR,y}$  = Baseline uncertain electricity generation in the grid or on-site or off-site power-only units in year y (MWh)

$EF_{EG,,}$  = Baseline uncertain electricity generation in the grid or on-site or off-site power-only units in year y (MWh)

$EF_{EG,FF,y}$  = CO<sub>2</sub> emission factor for electricity generation at the project site or off-site plants in the baseline in year y (t CO<sub>2</sub>/MWh)

$BE_{BR,y}$  = Baseline emissions due to disposal of biomass residues in year y (t CO<sub>2</sub>e)

$f$  = Fossil fuel type

Generation of captive thermal and electrical energy from its own by-products like bagasse is a common practice across the sugar mills. The fuel used for the project activity is entirely carbon neutral biomass residue. In absence of the project activity, plant would not have exported green power to grid and consequently other power plants which are dominated by fossil fuels would generate electricity and supply equivalent energy to grid. Hence the emission reduction can only be calculated for the replacement of equivalent grid- mix energy, which would be exported to grid by this project activity, with renewable electricity.

The equation reduces to:

$$BE_y = EL_{BL,GR,y} \times EF_{EG,GR,y}$$

Where,

$BE_y$  = Baseline emissions in year y (t CO<sub>2</sub>)

$EL_{BL,,}$  = Baseline electricity sourced from the grid in year y (MWh)

$EF_{EG,GR,y}$  = Grid emission factor in year y (t CO<sub>2</sub>/MWh)

Plant is exporting surplus energy to grid after captive consumption. Hence as per para 45 of the methodology,  $(EL_{BL,GR,y} - CAP_{EG,l,y})$  would be the quantity of electricity supplied to the grid by the project activity which is greater than zero.

Therefore,

**$EL_{BL,GR,y}$  = Net electricity exported to grid**

Referring to TOOL 16 “Project and leakage emissions from biomass”, the project and leakage emissions for the project activity are zero (0).

But as per the revised UCR CoU Standard;

$$PE_y = 10\% \text{ of } BE_y$$

Therefore,  $PE_y = 10\% \text{ of } BE_y$  and  $LE_y = 0$

**Estimated Annual or Total baseline emission reductions ( $BE_y$ ) = 17,496 CoUs /year (17,496 tCO<sub>2</sub>eq / year)**

## **B.6. Prior History>>**

The project activity has not applied to any other GHG program for registration or issuance of credits for the said crediting period. This is a green field project and has never got registered, de-registered or rejected in any other GHG emission reduction programme before. Also, the project has never been a part of any large scale project activity or a PoA.

## **B.7. Changes to start date of crediting period >>**

There is no change to the start date of crediting period.

## **B.8. Permanent changes from PCN monitoring plan, applied methodology or applied standardized baseline >>**

There are no permanent changes from registered PCN monitoring plan and applied methodology

## **B.9. Monitoring period number and duration>>**

The plant was commissioned in 24/12/2021 and the start date of crediting period is also considered from 24/12/2021.

Therefore, First Issuance Period: 2 years, 0 month – 24/12/2021 to 23/12/2023.

## **B.8. Monitoring plan>>**

Following parameter would be fixed ex-ante

Data/Parameter	$EF_{EG,GR,y}$
Data unit	t CO <sub>2</sub> /MWh
Description	Grid emission factor
Source of data	UCR standard (Version 6.0)
Values applied	0.9
Measurement methods and procedures	N/A

Monitoring frequency	Ex- ante fixed parameter
Purpose of data	For estimation of baseline emissions

Following parameter would be monitored ex-post

Data / Parameter:	$EL_{BL,GR,y}$
Data unit:	MWh
Description:	Net electricity exported to grid in year y
Source of data:	Joint meter readings (JMRs)
Measurement procedures (if any):	Data will be measured on- site via calibrated electricity meters
Monitoring frequency:	Monthly
QA/QC procedures:	Calibrations of the main meter will be carried out once in 5 years as per national standards (as per provision of CEA, India). Any faulty meters will be duly replaced immediately as per the provision of PPA. Cross checking Quantity of net electricity supplied to grid will be crossed checked from the invoices raised by the project participants to grid.
Any comment:	All the data will be archived till a period of 2 years from the end of the crediting period.